

Hydraulic Piston Clamp

Swing Clamp Rod

Model GN



Clamp rod swings to avoid interfering with the die when loading or unloading the lower die.

Clamps with hydraulic pressure + spring force, releases with air pressure.

Action Description

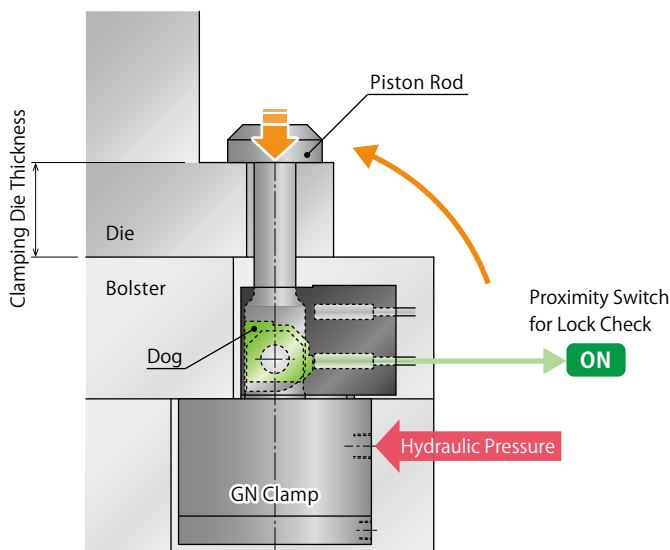

Locked Condition

By venting from air port, the piston rod swings with spring force. Supply hydraulic pressure to hydraulic port and the piston rod descends to lock the die.
Proximity switch for lock check detects the dog and makes a signal for lock check.

Proximity Switch for Lock Check	<input checked="" type="checkbox"/>
Proximity Switch for Swing Check	<input type="checkbox"/>

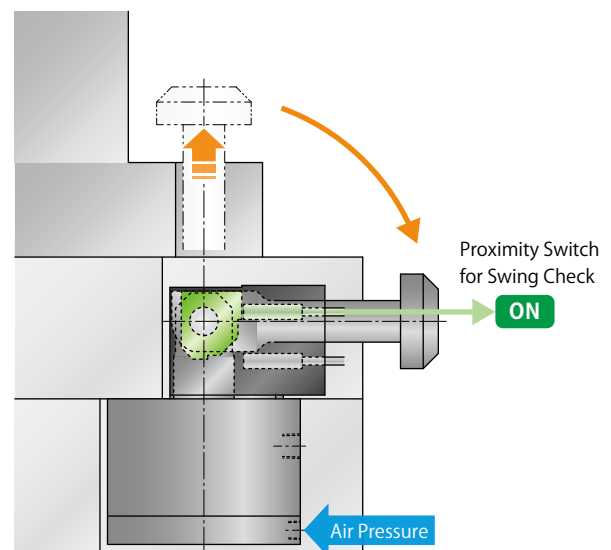

Released / Swinged Condition

Release hydraulic pressure and supply air pressure. The piston rod ascends to swing and release action is completed.
Proximity switch for swing check detects the dog and makes a signal for lock check.

Proximity Switch for Lock Check	<input type="checkbox"/>
Proximity Switch for Swing Check	<input checked="" type="checkbox"/>

We provide GN clamps according to clamping die thickness. Refer to the external dimensions for detail.

● **Circuit Reference / Action Description**

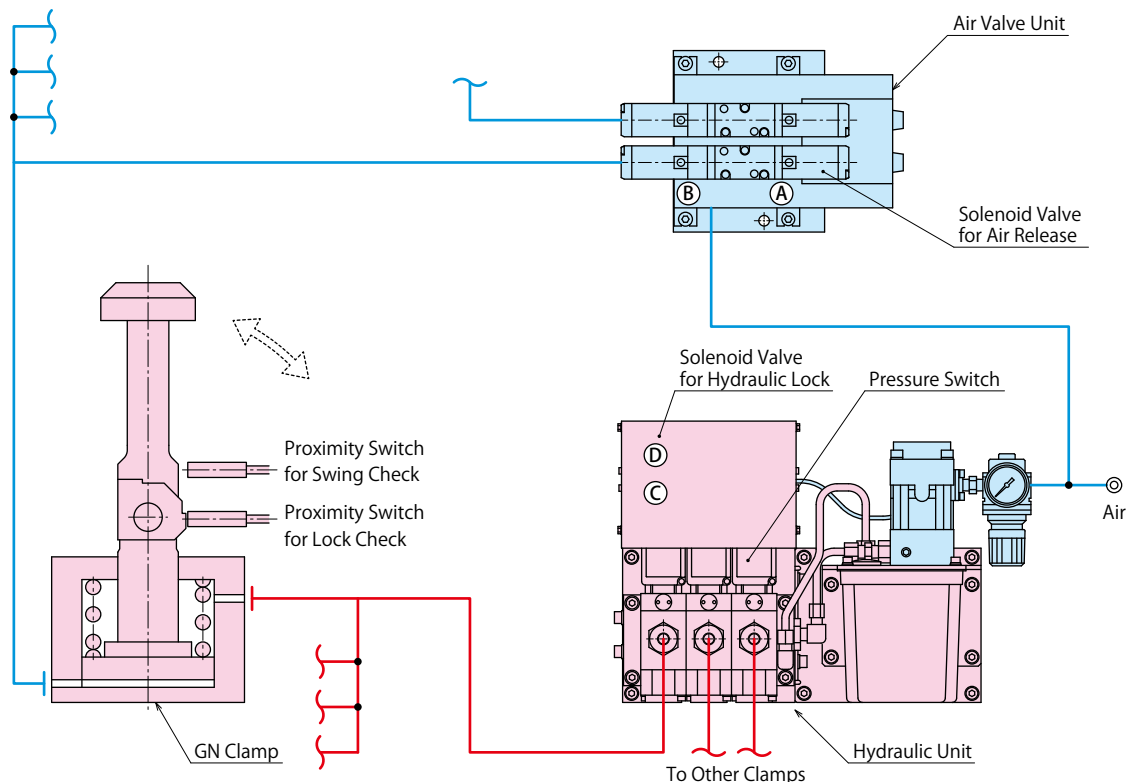

Clamp Hydraulic Unit
Operation Control Panel

Die Lifter
Pre-Roller

Accessories

Cautions
Company Profile

Clamp

GA
GD
GB
GE
GP
GN

Hydraulic Unit

CP
CR
CS

Pump Unit

CB
CD
CC

Valve Unit

BC
BH
MV

Operational Control Panel

YP
YA

● **Release → Lock**

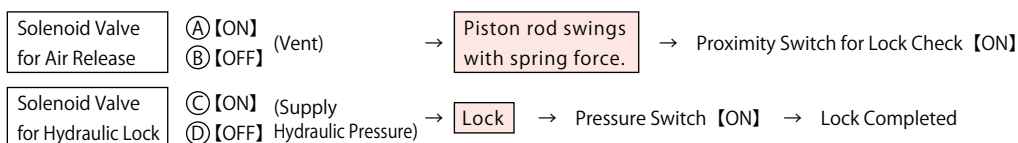

※ Lock action is completed when both proximity switch for lock check and pressure switch are [ON].

● **Lock → Release**

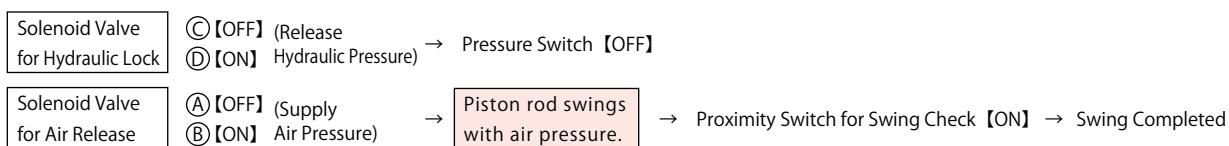

※ Release/Swing actions are completed when proximity switch for swing check is [ON] and pressure switch is [OFF]

Notes

1. Although GN clamp is a hydraulic single action clamp, the unit circuit of the clamp is the **U** circuit because the clamp is controlled with double solenoid. When using GN clamp combining with other single action clamps, the clamp circuit should be **G** circuit. When using GN clamp combining with RA die lifters, the circuit should be **H** circuit. Please contact us for more information.

● **U-Cut Dimensions**

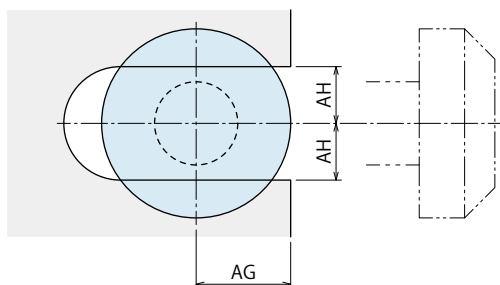

	(mm)			
Model No.	GN0251	GN0401	GN0631	GN1001
AG	9~20	11~25	14~30	17~37.5
AH	max. 12	max. 16	max. 19	max. 23

Note

1. Please consider this drawing for U-Cut dimensions and locating accuracy of GN clamp and the die.

Model No. Indication

GN 040 1 - 35 - 5 - V

1 2 3 4 5

1 Clamping Force

025 : 24.5kN
040 : 39.2kN
063 : 61.7kN
100 : 98.0kN

4 Proximity Switch Load Voltage (Current)

1 : AC100V
2 : AC200V
5 : DC24V (5~40mA)

2 Design No.

1 : Revision Number

5 Option

Blank : Standard

N : NPT Port Type^{※3}

V : High Temperature Type (0~120°C)

※3. For **N**:NPT port type, each dimension is described in "inch" in the specifications and other documents.

3 Die Thickness (h Dimension)^{※1 ※2}

25 : Die Thickness (h Dimension) = 25mm
 }

50 : Die Thickness (h Dimension) = 50mm

※1. The Die thickness (h dimension) can be selected from the range of 25~50mm.

※2. For **5** Option **N**:NPT port type each dimension is described in "inch" in the specifications and other documents.

However the die thickness is shown by mm value as a symbol.

Specifications

Model No.		GN0251	GN0401	GN0631	GN1001
Clamping Force	kN	24.5	39.2	61.7	98
Working Pressure	MPa	24.5 (For Rated Clamp Force)			
Max. Operating Pressure	MPa	27.0			
Withstanding Pressure	MPa	36.8			
Full Stroke	mm	6	7.5	10	12
Clamp Stroke	mm	4	5	7	9
Extra Stroke	mm	2	2.5	3	3
Swing Angle		90°			
Cylinder Capacity	Lock	18.6	36	73.9	157.9
	cm ³ Release	27.4	53.5	115.5	241.8
Air Pressure for Swing Action	MPa	0.39 ~ 0.49			
Proximity Switch Voltage		AC100V / AC200V / DC24V			
Operating Temperature ^{※4}	°C	0 ~ 70 (V : High temperature type is available for 0 ~ 120°C)			
Use Frequency ^{※5}		Less than 20 cycles / day ^{※5}			
Usable Fluid ^{※6}		ISO-VG-32 or equivalent			

Notes 1. Hydraulic pressure for lock should be 24.5MPa, and air pressure for release should be 0.39 ~ 0.49MPa.

2. GN clamp is not applicable to the upper die or the place where the swing rod is downward.

※4. **V** : High temperature type is available for 0 ~ 120°C

※5. Please contact us for more frequent use.

※6. Please contact us for fluids other than those mentioned on the list.

External Dimensions

The drawing shows the clamped condition of **5** Option "Blank : Standard" in the model No. indication.

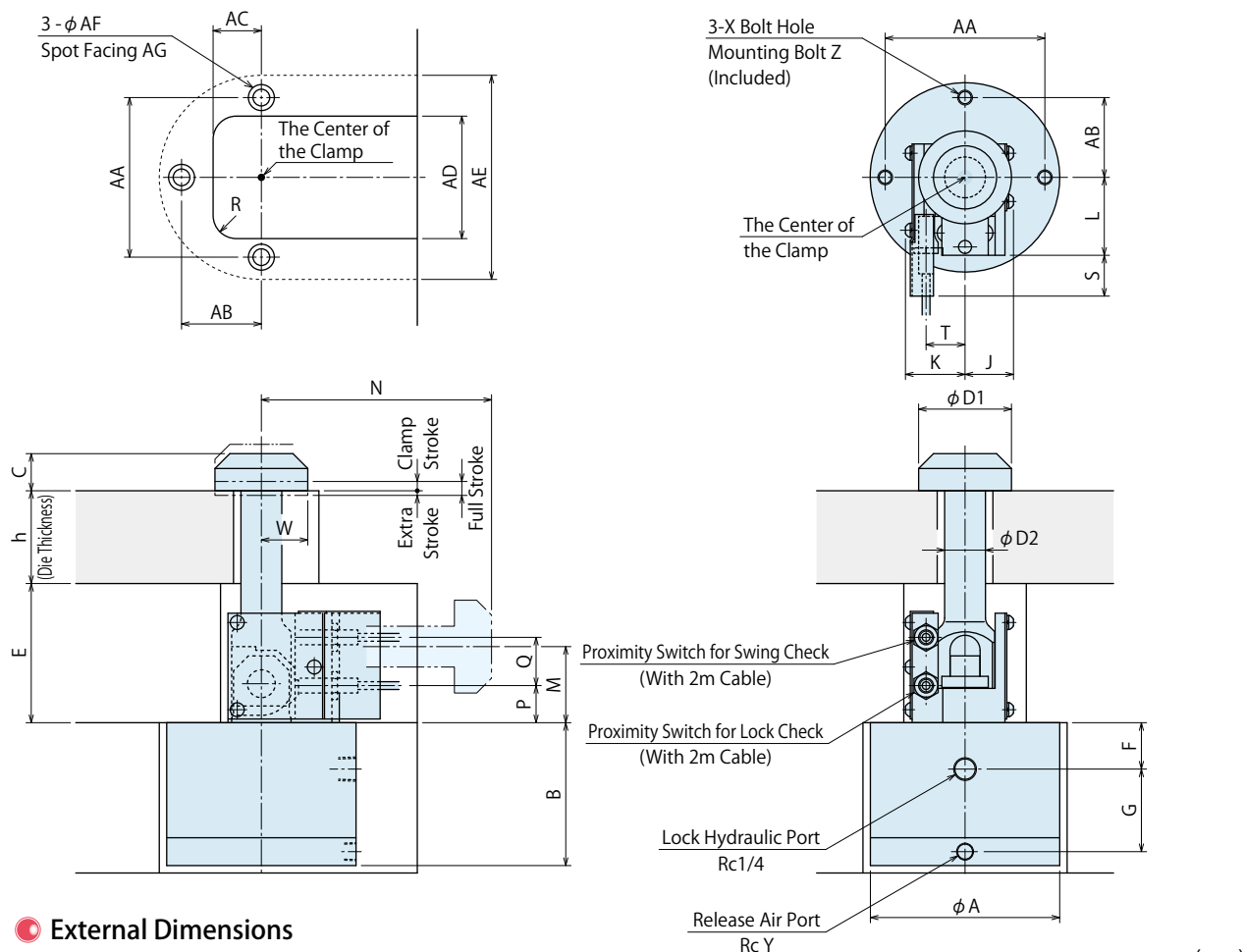

External Dimensions

(mm)

Model No.	GN0251	GN0401	GN0631	GN1001
Full Stroke	6	7.5	10	12
Clamp Stroke	4	5	7	9
Extra Stroke	2	2.5	3	3
A	83	102	122	142
B	71.5	77	90.5	111
C	16	20	25	35
D1	40	50	60	75
D2	18	22	28	34
E	60	75	90	115
F	24	25	26.5	30
G	40	44.5	54	70
J	22.5	26	32.5	40
K	28.5	32	38.5	49
L	35	42	49	60
M	33.5	41	53	67
N	h+58.5	h+74	h+89	h+118
P	16.5	20	24	31
Q	21	26	34	39
R	10	12.5	15	17.5
S	18	22	24	17
T	18	21	26.5	35
W	20	25	30	37.5
X	M6 Thread Depth12	M8 Thread Depth16	M8 Thread Depth16	M8 Thread Depth16
Y	Rc1/8	Rc1/8	Rc1/8	Rc1/4
Z	M6 x 60	M8 x 75	M8 x 90	M8 x 115
AA	72	86	106	126
AB	36	43	53	63
AC	23	27	35	40
AD	58	67	84	104
AE	90	110	130	150
AF	7	9	9	9
AG	phi 11 Depth 7	phi 14 Depth 9	phi 14 Depth 9	phi 14 Depth 9
h ^{※7}	25 ~ 50	25 ~ 50	25 ~ 50	25 ~ 50

Notes

1. This external dimensions are for **5** Option "Blank : Standard" in the model No. indication.
Please contact us for external dimensions for options.
 2. Clamp surface must be level with clamp mounting surface.
 3. Take care to prevent dusts, sand, chips, slugs, etc from entering clamp mechanism.
- ※7. Allowance of die thickness should be $h \pm 5\text{mm}$.

Clamp
Hydraulic Unit
Operation Control Panel

Die Lifter
Pre-Roller

Accessories

Cautions
Company Profile

Clamp

GA

GD

GB

GE

GP

GN

Hydraulic Unit

CP

CR

CS

Pump Unit

CB

CD

CC

Valve Unit

BC

BH

MV

Operational Control Panel

YP

YA

Cautions

Notes for Design

1) Check the specifications

- Please use each product according to the specifications.
- Operating pressure is 24.5MPa.
Operating pressure of GN clamp : Hydraulic pressure for locking is 24.5MPa. Pneumatic pressure for releasing is 0.39~0.49MPa.
Do not use clamps with pressure that is above the operating pressure.
Falling down of the die due to the damage on clamps leads to injury accident.
In order to reduce clamping force, use them with lower operating pressure.

2) Check the thickness of the die clamping part.

- Please check the thickness of the die clamping part.
The thickness of the die clamping part of GN clamp should be $h \pm 0.5\text{mm}$.
If using dies other than prescribed, clamps cannot conduct locking action normally and it leads to accident or injury.

3) Clamp surface and T-slot must be parallel to mounting surface of the die.

- If clamp surface is not even or parallel, excessive force is applied to the clamp and it deforms main body and lever of the clamp resulting in accident or injury.

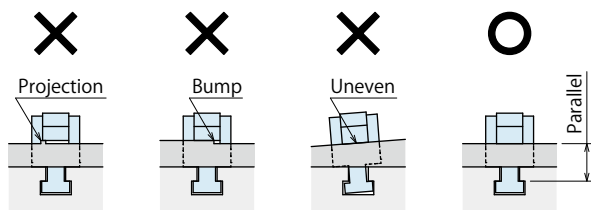

4) Make sure that advance/retraction of the clamp is smoothly conducted. (Model GD / GE)

- Please control air cylinder for slide with two-position double solenoid (with detent).
- Supply more than 0.39MPa air pressure to air cylinder.
- Please adjust the moving speed of the clamp with speed controller to be fully stroked within 1 to 2 seconds.
- Do not set the proximity switch to the die surface near the U-cut, since it is used as forward-end detection.
- The clamp sliding surface must be smooth (without any bumps).

5) Make sure that dust, sand, cutting chips or blank pieces do not enter the clamp.

- Clamp does not operate smoothly and may be damaged.

6) When the clamp cylinder sticks out of U-cut or T-slot, please use it within the allowable protrusion amount.

- U-cut of the die . . . Model GA / GD
- T-slot of the slider / bolster . . . Model GB / GE

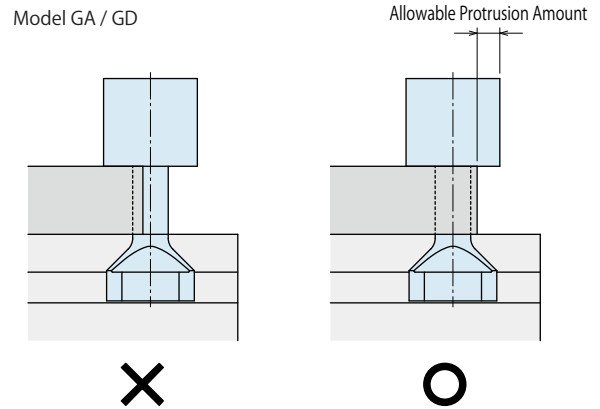

Allowable Protrusion Amount

Model No.	Allowable Protrusion Amount (mm)
GA0100	13
GA0160	14
GA0250 / GD0250	17
GA0400 / GD0400	20
GA0630 / GD0630	26
GA1000 / GD1000	32
GA1600 / GD1600	42
GA2500	50

Model GB / GE

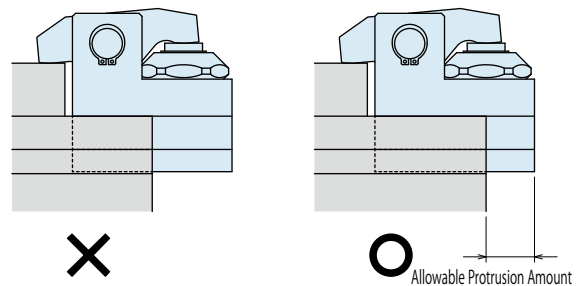

Allowable Protrusion Amount

Model No.	Allowable Protrusion Amount (mm)
GB0100	17.5
GB0160	21
GB0250 / GE0251	25
GB0400 / GE0401	32
GB0630 / GE0631	39
GB1000 / GE1001	45
GB1600 / GE1601	57
GB2500 / GE2501	69.5

7) Be careful with mounting position of the clamp (Model GP only)

- Make sure that main body of the clamp is not out of the mounting surface.
Excessive force is applied to the clamp and it deforms the clamp or damages mounting bolt resulting in falling off of the die and accident or injury.

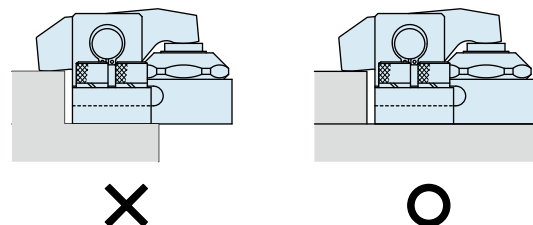

● Notes on Installation

- 1) Check the fluid to use
 - Please use the appropriate fluid by referring to the Hydraulic Fluid List.
 - If using hydraulic oil having viscosity higher than viscosity grade ISO-VG-32, action time will be longer.
 - If using it at low temperature, action time will be longer because the viscosity of hydraulic oil becomes higher.
- 2) Procedure before piping
 - The pipeline, piping connector and fixture circuits should be cleaned by thorough flushing. The dust and cutting chips in the circuit may lead to fluid leakage and malfunction. (The filter which removes contaminant in the hydraulic piping or hydraulic system is not provided.)
- 3) Applying sealing tape
 - Wrap with tape 1 to 2 times following the screwing direction. When piping, be careful that contaminants such as sealing tape do not enter in products. Pieces of the sealing tape can lead to oil leaks and malfunction.
- 4) Air bleeding in the hydraulic circuit
 - If the hydraulic circuit has excessive air, the action time may become very long. If air enters the circuit after connecting the hydraulic port or under the condition of no air in the oil tank, please conduct air bleeding with the end of the piping.
 - ① Reduce hydraulic supply pressure to less than 2MPa.
 - ② Please loosen the cap nut of pipe fitting that is closest to clamps by one full turn.
 - ③ Wiggle the pipeline to loosen the outlet of pipeline fitting. The hydraulic fluid mixed with air comes out.

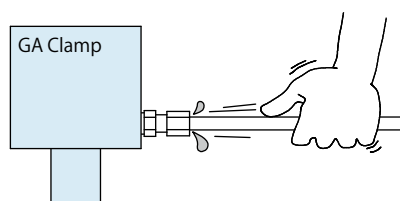

- ④ Tighten the cap nut after bleeding.
 - ⑤ It is more effective to bleed air at the highest point inside the circuit or at the end of the circuit.
- 5) Checking looseness and retightening
 - At the beginning of the machine installation, the bolt/nut may be tightened lightly. Check torque and re-tighten as required.

- 6) Mounting the clamp
 - After setting the clamp in the T-slot, use attached hex. socket bolts and tighten it with the torque shown below (Model GD / GE)

Model No.	Thread Size	Tightening Torque (N·m)
GD0250	M6	10
GD0400	M6	10
GD0630	M6	10
GD1000	M8	25
GD1600	M8	25

Model No.	Thread Size	Tightening Torque (N·m)
GE0251	M5	6.3
GE0401	M5	6.3
GE0631	M6	10
GE1001	M8	25
GE1601	M10	50
GE2501	M12	80

- Use attached hex. socket bolts and tighten it with the torque shown below (Model GN / GP)

Model No.	Thread Size	Tightening Torque (N·m)
GP0100	M8	25
GP0160	M10	50
GP0250	M12	80
GP0400	M14	125
GP0630	M16	200
GP1000	M20	400
GP1600	M24	630

Model No.	Thread Size	Tightening Torque (N·m)
GN0251	M6	12
GN0401	M8	30
GN0631	M8	30
GN1001	M8	30

- 7) Wiring of the forward-end detection switch
 - Make sure there is enough slack in the wire so that the clamp can complete the sliding action without putting tension on the wire.

● Hydraulic Fluid List

Maker	ISO Viscosity Grade ISO-VG-32	
	Anti-Wear Hydraulic Oil	Multi-Purpose Hydraulic Oil
Showa Shell Sekiyu	Tellus S2 M 32	Morlina S2 B 32
Idemitsu Kosan	Daphne Hydraulic Fluid 32	Daphne Super Multi Oil 32
JX Nippon Oil & Energy	Super Hyrando 32	Super Mulpus DX 32
Cosmo Oil	Cosmo Hydro AW32	Cosmo New Mighty Super 32
ExxonMobil	Mobil DTE 24	Mobil DTE 24 Light
Matsumura Oil	Hydol AW-32	
Castrol	Hyspin AWS 32	

Note As it may be difficult to purchase the products as shown in the table from overseas, please contact the respective manufacturer.

※ Please refer to P.145 for common caution.

• Speed Control Circuit of Hydraulic Cylinder & Notes
 • Maintenance / Inspection • Warranty

Cautions

Notes on Handling

- 1) Shutting down of the machine should be done without load applied to the clamp.
 - This can result in the dropping of a mold / die.
 - When using it with a press machine, make sure to stop the slide at bottom dead point.
- 2) It should be handled by qualified personnel.
 - The hydraulic machine/air compressor should be handled and maintained by qualified personnel.
- 3) Do not handle or remove the machine unless the safety is ensured.
 - ① The machine and equipment can only be inspected or prepared when it is confirmed that the preventive devices are in place.
 - ② Before the machine is removed, make sure that the above-mentioned safety measures are in place. Shut off the air of hydraulic source and make sure no pressure exists in the hydraulic and air circuit.
 - ③ After stopping the machine, do not remove until the temperature cools down.
 - ④ Make sure there is no abnormality in the bolts and respective parts before restarting the machine or equipment.
- 4) Do not touch clamps while they are working.
 - Otherwise, your hands may be injured.

- 7) Do not disassemble or modify it.
 - If the equipment is taken apart or modified, the warranty will be void even within the warranty period.
- 8) Please do not pour water / oil over the product.
 - It may lead to malfunction or deterioration of the product and cause an accident.

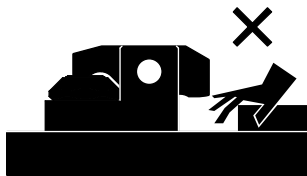
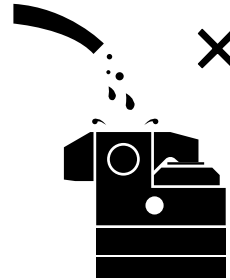

- 5) When changing the width of the die, make sure to check the allowable protrusion amount.
 - If using it with beyond allowable protrusion amount, excessive force is applied to the clamp which deforms or damages the clamp resulting in falling off of the die and accident or injury. Please refer to "Notes for Design (6)" on P.041 for the allowable protrusion amount.
- 6) Please hold the main body of the clamp when moving or removing it.
 - If pulling on hydraulic hose or air tube, the clamp will fall off leading to accident or injury. Also, rivet part of the hose will be loosened leading to fluid leakage.

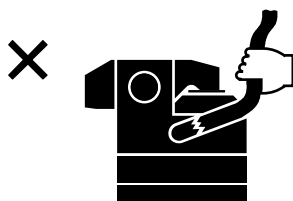

※ Please refer to P.145 for common caution.

• Speed Control Circuit of Hydraulic Cylinder & Notes
 • Maintenance / Inspection • Warranty

Clamp
Hydraulic Unit
Operation Control Panel

Die Lifter
Pre-Roller

Accessories

Cautions
Company Profile

Clamp

GA

GD

GB

GE

GP

GN

Hydraulic Unit

CP

CR

CS

Pump Unit

CB

CD

CC

Valve Unit

BC

BH

MV

Operational Control Panel

YP

YA

● Cautions

● Notes on Installation (Cautions for Hydraulic Series)

1) Check the fluid to use

- Please use the appropriate fluid by referring to the Hydraulic Fluid List.
- If hydraulic oil with viscosity grade higher than ISO-VG-32 is used, action time would be longer.
- If using it at low temperature, action time will be longer because the viscosity of hydraulic oil becomes higher.

2) Procedure before piping

- The pipeline, piping connector and fixture circuits should be cleaned by thorough flushing.
- The dust and cutting chips in the circuit may lead to fluid leakage and malfunction.
- Our products except some valves are not equipped with protective function to prevent dust and cutting chips going into the hydraulic system and pipeline.

3) Applying sealing tape

- Wrap with tape 1 to 2 times following the screwing direction.
- Pieces of the sealing tape can lead to air leaks and malfunction.
- In order to prevent a foreign substance from going into the product during piping, it should be carefully cleaned.

4) Air bleeding in the hydraulic circuit

- If the hydraulic circuit has excessive air, the action time may become very long.
After installing the hydraulic circuit, or if the pump run out of oil, be sure to bleed air by the following step.
- ① Reduce hydraulic supply pressure to less than 2MPa.
- ② Please loosen the cap nut of pipe fitting that is closest to clamps · RA die lifters by one full turn.
- ③ Wiggle the pipeline to loosen the outlet of pipeline fitting.
The hydraulic fluid mixed with air comes out.

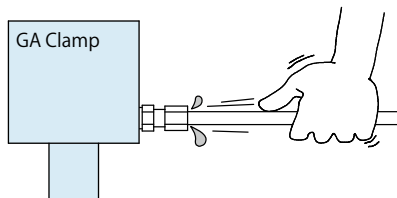

- ④ Tighten the cap nut after bleeding.
- ⑤ It is more effective to bleed air at the highest point inside the circuit or at the end of the circuit.

5) Checking looseness and retightening

- At the beginning of the machine installation, the bolt/nut may be tightened lightly.
Check torque and re-tighten as required.

● Hydraulic Fluid List

Maker	ISO Viscosity Grade ISO-VG-32	
	Anti-Wear Hydraulic Oil	Multi-Purpose Hydraulic Oil
Showa Shell Sekiyu	Tellus S2 M 32	Morlina S2 B 32
Idemitsu Kosan	Daphne Hydraulic Fluid 32	Daphne Super Multi Oil 32
JX Nippon Oil & Energy	Super Hyrando 32	Super Mulpus DX 32
Cosmo Oil	Cosmo Hydro AW32	Cosmo New Mighty Super 32
ExxonMobil	Mobil DTE 24	Mobil DTE 24 Light
Matsumura Oil	Hydol AW-32	
Castrol	Hyspin AWS 32	

Note As it may be difficult to purchase the products as shown in the table from overseas, please contact the respective manufacturer.

● Speed Control Circuit of Hydraulic Cylinder and Notes



If the hydraulic cylinder speed is controlled, the circuit should be designed with the following points taken into consideration. Review these notes prior to installation as the wrong circuit design may lead to machine malfunction and damage.

● Flow control circuit for single acting cylinder.

For spring return type single acting cylinders, restricting flow during release can extremely slow down or prevent release action. The preferred method is to control the flow during the lock action and use a valve that has free-flow in the release direction.

Also, it is preferred to provide a flow control valve at each actuator.

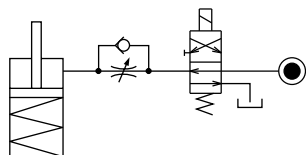

If the release action is accelerated by excessive hydraulic flow the cylinder may sustain damage. In this case add flow control to regulate flow.

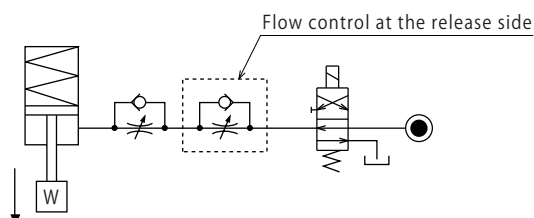

● Flow control circuit for double acting cylinder.

Flow control circuit for double acting cylinder should have meter-out circuits for both the lock and release sides. Meter-in control can have adverse effect by presence of air in the system.

【Meter-out circuit】

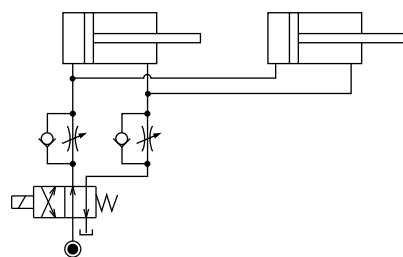

【Meter-in circuit】

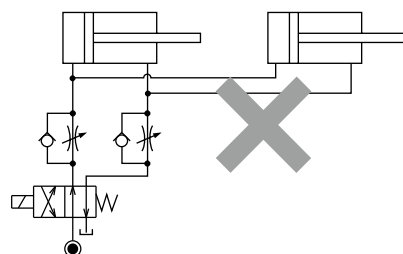

In the case of meter-out circuit, the hydraulic circuit should be designed with the following points.

- ① Single acting components should not be used in the same flow control circuit as the double acting components. The release action of the single acting cylinders may become erratic or very slow.

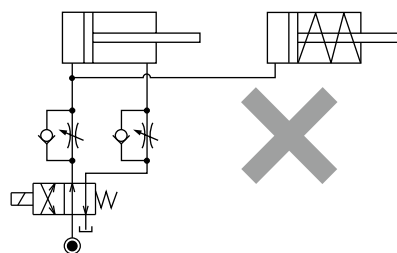

Refer to the following circuit when both the single acting cylinder and double acting cylinder are used together.

- Separate the control circuit.

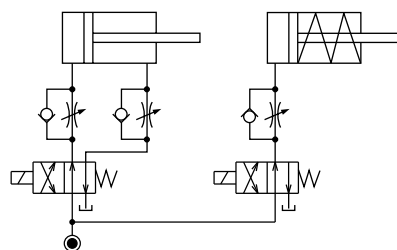

- Reduce the influence of double acting cylinder control unit. However, due to the back pressure in tank line, single action cylinder is activated after double action cylinder work.

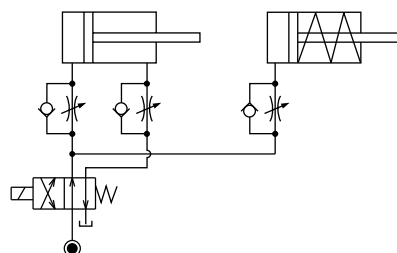

- ② In the case of meter-out circuit, the inner circuit pressure may increase during the cylinder action because of the fluid supply. The increase of the inner circuit pressure can be prevented by reducing the supplied fluid beforehand via the flow control valve. Especially when using sequence valve or pressure switches for clamping detection, if the back pressure is more than the set pressure then the system will not work as it is.

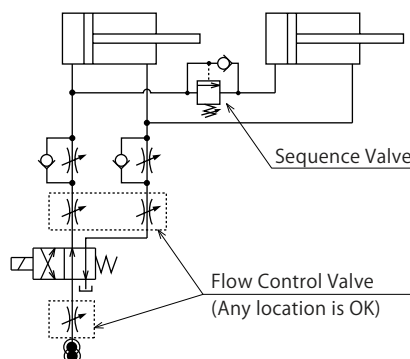

● Cautions

● Notes on Handling

- 1) It should be handled by qualified personnel.
 - The hydraulic machine / air compressor should be handled and maintained by qualified personnel.
- 2) Do not handle or remove the machine unless the safety is ensured.
 - ① The machine and equipment can only be inspected or prepared when it is confirmed that the preventive devices are in place.
 - ② Before the machine is removed, make sure that the above-mentioned safety measures are in place. Shut off the air of hydraulic source and make sure no pressure exists in the hydraulic and air circuit.
 - ③ After stopping the machine, do not remove until the temperature cools down.
 - ④ Make sure there is no abnormality in the bolts and respective parts before restarting the machine or equipment.
- 3) Do not touch clamps (cylinders) while they are working. Otherwise, your hands may be injured.

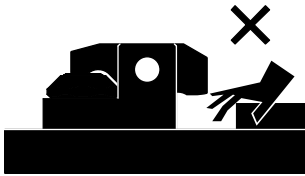

- 4) Do not disassemble or modify it.
 - If the equipment is taken apart or modified, the warranty will be void even within the warranty period.

● Maintenance • Inspection

- 1) Removal of the machine and shut-off of pressure source
 - Before the machine is removed, make sure that the above-mentioned safety measures are in place. Shut off the air of hydraulic source and make sure no pressure exists in the hydraulic and air circuit.
 - Make sure there is no abnormality in the bolts and respective parts before restarting.
- 2) Regularly clean the area around the equipment.
 - If it is used when the surface is contaminated with dirt, it may lead to packing seal damage, malfunctioning, fluid leakage and air leaks.

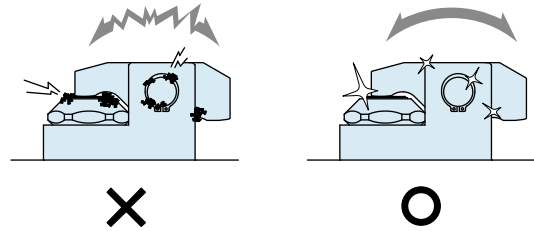

- 3) If disconnecting by couplers on a regular basis, air bleeding should be carried out daily to avoid air mixed in the circuit.
- 4) Regularly tighten bolts and pipe line, mounting bolts, nuts, circlips and cylinders to ensure proper use.
- 5) Make sure the hydraulic fluid has not deteriorated.
- 6) Make sure there is smooth action and no abnormal noise.
 - Especially when it is restarted after left unused for a long period, make sure it can be operated properly.
- 7) The products should be stored in the cool and dark place without direct sunshine or moisture.
- 8) Please contact us for overhaul and repair.

● Warranty

1) Warranty period

- The product warranty period is 18 months from shipment from our factory or 12 months from initial use, whichever is earlier.

2) Warranty scope

- If the product is damaged or malfunctions during the warranty period due to faulty design, materials or workmanship, we will replace or repair the defective part at our expense. Defects or failures caused by the following are not covered.

- ① If the stipulated maintenance and inspection are not carried out.
- ② If the product is used while it is not suitable for use based on operator judgment, resulting in defect.
- ③ If it is used or handled in inappropriate way by the operator. (Including damage caused by the misconduct of a third party.)
- ④ If the defect is caused by reasons other than our responsibility.
- ⑤ If repair or modifications are carried out by anyone other than Kosmek, or without our approval and confirmation, it will void warranty.
- ⑥ Defects caused by natural disasters or calamities not attributable to our company.
- ⑦ Parts expenses or replacement expenses due to parts consumption and deterioration. (Such as rubber, plastic, seal material and some electric components.)

Damages from direct result of a product defect shall be excluded from the warranty.

Clamp
Hydraulic Unit
Operation Control Panel

Die Lifter
Pre-Roller

Accessories

Cautions
Company Profile

Cautions

Notes on Installation
(For Hydraulic Series)

Hydraulic Fluid List

Speed Control Circuit of
Hydraulic Cylinder & Notes

Notes on Handling

Maintenance / Inspection

Warranty

Company Profile

Company Profile

Our Products

History

Sales Office

Sales Office

Sales Offices Across the World

Japan Overseas Sales	TEL. +81-78-991-5162	FAX. +81-78-991-8787
	KOSMEK LTD. 1-5, 2-chome, Murotani, Nishi-ku, Kobe-city, Hyogo, 651-2241, Japan 〒651-2241 兵庫県神戸市西区室谷2丁目1番5号	
USA KOSMEK (USA) LTD.	TEL. +1-630-241-3465	FAX. +1-630-241-3834
	1441 Branding Avenue, Suite 110, Downers Grove, IL 60515 USA	
China KOSMEK (CHINA) LTD. 考世美(上海)貿易有限公司	TEL. +86-21-54253000	FAX. +86-21-54253709
	21/F, Orient International Technology Building, No.58, Xiangchen Rd, Pudong Shanghai 200122., P.R.China 中国上海市浦东新区向城路58号东方国际科技大厦21F室 200122	
Thailand Thailand Representative Office	TEL. +66-2-715-3450	FAX. +66-2-715-3453
	67 Soi 58, RAMA 9 Rd., Suanluang, Suanluang, Bangkok 10250, Thailand	
Europe (Europe Exclusive Distributors) KOS-MECH GmbH	TEL. +43-463-287587-10	FAX. +43-463-287587-20
	Schleppeplatz 2 9020 Klagenfurt Austria	
Taiwan (Taiwan Exclusive Distributors) Full Life Trading Co., Ltd. 盈生貿易有限公司	TEL. +886-2-82261860	FAX. +886-2-82261890
	16F-4, No.2, Jian Ba Rd., Zhonghe District, New Taipei City Taiwan 23511 台湾新北市中和區建八路2號 16F-4 (遠東世紀廣場)	
Philippines (Philippines Exclusive Distributors) G.E.T. Inc, Phil.	TEL.+63-2-310-7286	FAX. +63-2-310-7286
	Victoria Wave Special Economic Zone Mt. Apo Building, Brgy. 186, North Caloocan City, Metro Manila, Philippines 1427	
Indonesia (Indonesia Exclusive Distributors) P.T PANDU HYDRO PNEUMATICS	TEL.+62-21-5818632	FAX. +62-21-5814857
	Ruko Green Garden Blok Z- II No.51 Rt.005 Rw.008 Kedoya Utara-Kebon Jeruk Jakarta Barat 11520 Indonesia	

Sales Offices in Japan

Head Office Kansai Office Overseas Sales	TEL. +81-78-991-5162	FAX. +81-78-991-8787
	KOSMEK LTD. 1-5, 2-chome, Murotani, Nishi-ku, Kobe-city, Hyogo, 651-2241, Japan 〒651-2241 兵庫県神戸市西区室谷2丁目1番5号	
Kanto Office	TEL. +81-48-652-8839	FAX. +81-48-652-8828
	KOSMEK LTD. 81, 4-chome, Onari-cho, Kita-ku, Saitama City, Saitama, 331-0815, Japan 〒331-0815 埼玉県さいたま市北区大成町4丁目81番地	
Chubu Office	TEL. +81-566-74-8778	FAX. +81-566-74-8808
	KOSMEK LTD. 10-1, 2-chome, Misono-cho, Anjo City, Aichi, 446-0076, Japan 〒446-0076 愛知県安城市美園町2丁目10番地1	
Kyusyu Office	TEL. +81-92-433-0424	FAX. +81-92-433-0426
	KOSMEK LTD. 8-10-101, 1-chome, Kamimuta, Hakata-ku, Fukuoka City, Fukuoka, 812-0006, Japan 〒812-0006 福岡県福岡市博多区上牟田1丁目8-10-101	